



Project No: **CO0694**

Re: **Triton MQ and Pajero Sport Upper Control Arm
(UCATRITMQF)
Finite Element Analysis Engineering Report**

Certification Number: **0694-20180815-01**

Prepared for:

The logo for CalOffroad is rendered in a large, bold, stylized font. The letters are thick and have a 3D, blocky appearance with a dark grey fill and a lighter grey outline. The "C" and "O" are particularly prominent.

Date: **15th August 2018**

15th August 2018

Project No: C00694-1
Triton MQ and Pajero Sport Upper Control Arm (UCATRITMQF)
1260kg standard front axle rating to VSB14

To whom it may concern,

As requested, we have assessed the Triton MQ and Pajero Sport aftermarket upper control arm to VSB14 loads for a standard front axle rating of 1260kg using FEA analysis. This analysis was based on geometry developed from a supplied fabricated prototype arm. Details of this design and the FEA analysis results are described in the following project data:

- Analysis Report: 0694-20180815-01

A brief overview of the upper control design is provided over-page.

Only the upper control arm design has been assessed and the remainder of the front suspension has not been considered as part of this analysis. Furthermore, this analysis only considers the VSB14 loads and is in no way an assessment of the overall durability or manufacturing quality.

Finite Element Analysis (FEA) has been used to assess the performance of upper control arm design subject to loads and limits set out in the following reference documents:

- VSB14 "National Code of Practice for Light Vehicle Construction and Modification"

Based on the loading conditions and material properties used, the upper control arm design is considered to comply with the strength requirements of VSB14 for a maximum standard front axle rating of 1260kg under the following conditions:

1. The upper control arm tube sections, plates and gussets of 291MPa capacity with nominal minimum dimensions as per the specification.
2. All welds are performed subject to any relevant standards for the intended application.
3. Full details of the analysis and results are provided in report 0694-20180815-01, and any other conditions or requirements specified in the most recent version of that report must also be implemented

Kind Regards,

Brett Longhurst,
Managing Director,
Bremar Automotion Australia Pty Ltd

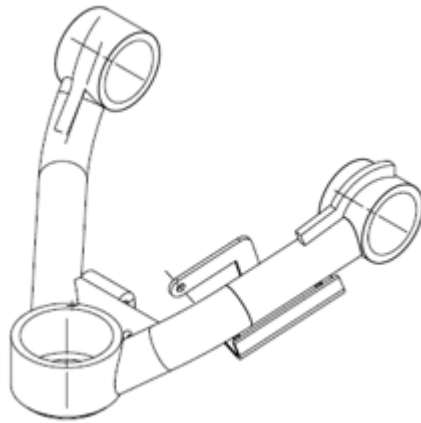

Figure 1: Upper Control Arm Design

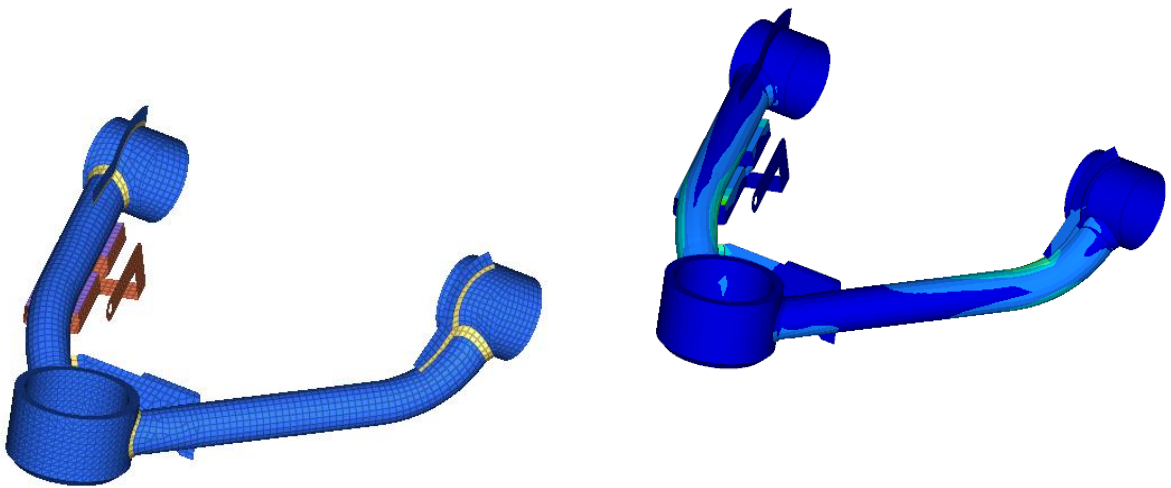

Figure 2: Upper Control Arm Mesh and Stress Contour